



**BeBrave** is a game that makes playtime even more exciting! It brings elements of the virtual world to the playground and combines traditional activity with a new, educational challenge.









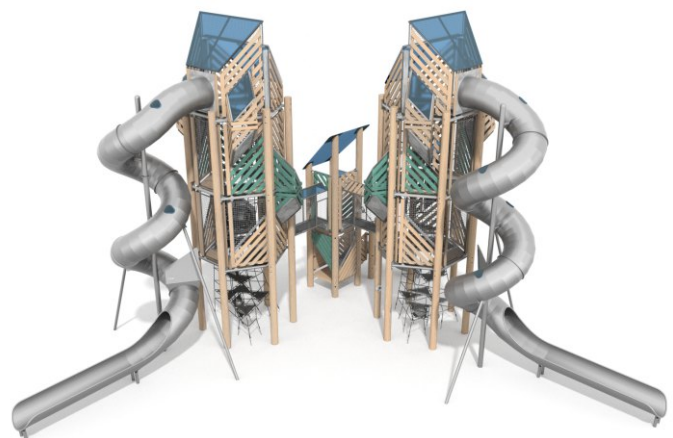

### Information about the product

Dimensions	ca. 1615 x 1333 cm
Safety zone	ca. 1826 x 1584 cm
Safety zone area	ca. 113,2 m <sup>2</sup>
Overall height	ca. 880 cm
Free fall height	210 cm
Amount of users	70
Highest element	770 cm
Heaviest element	400 kg
Product complies with EN 1176-1:2017-12	Yes
Availability of spare parts	Yes
Age range	3-12

According to EN 1176-1:2017-12 norm, the product requires applying a safety surface according to the product's free fall height.



### Functions

-  Climbing
-  Socializing
-  Grasping
-  Sliding
-  Emotion regulation
-  Courage
-  Logical thinking
-  Educational boards
-  Role-playing

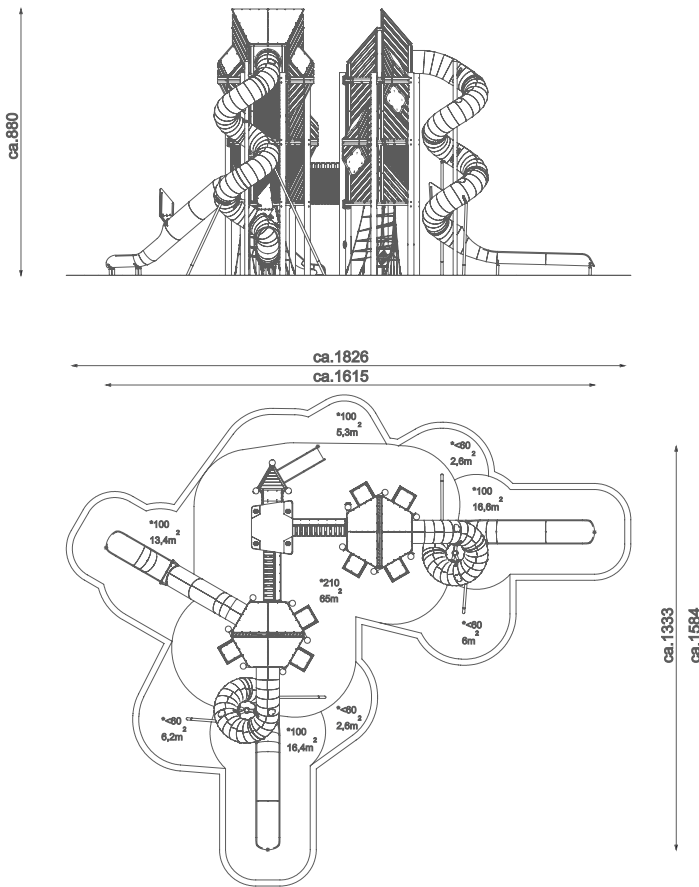

Due to the height of the free fall of the product, the EN 1176-1:2017-12 norm allows following types of fall- absorbing surfaces:

Material	Description	Minimal layer thickness mm
Bark	Chipped bark of coniferous trees (no wood-based materials), the size of the pieces between 20mm to 80mm	300
Wood chips	Mechanically fragmented wood without bark and leaves, size of the pieces between 5 mm to 30	300
Sand or gravel	Particle size between 0,25 mm to 8 mm	300
Synthetic material	Synthetic material with an approval for free fall heights $\geq 210$ cm	

All types of surfaces need to be preserved by adding bulk material and removing extraneous matters. Broken glass is considered to be most hazardous.

1:250

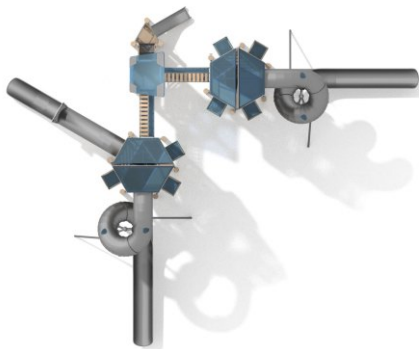

### Installation method

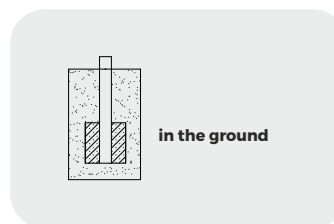

### Warranty



#### Lifetime

The warranty covers the durability of components made of HDPE (high-density polyethylene), as well as the structural integrity of components made of black steel that has been powder galvanised and powder coated, stainless steel, and components made of hot-dip galvanised steel.



#### 10 years

The Guaranty covers all flaws of the elements made of HPL, HDPE, stainless steel, hot-dip galvanized steel, wooden elements (pine, spruce), revealed during usage, which arise from manufacturing reasons.



#### 5 years

The Guaranty covers all flaws of the elements made of powder coated steel, aluminum, laminate, ropes, elements made in rotomoulding technology, elements made of polyamid, polypropylene elements, revealed during usage, which arise from manufacturing reasons.



#### 2 years

The Guaranty covers all flaws of the elements made of rubber, moving elements ( bearings, joints), electronic elements, elements made of EPDM, elements made of plywood and other not mentioned before revealed during usage, which arise from manufacturing reasons.

## Product description

---

### Dimensions:

- Equipment Dimensions: ca. 1615 x 1333 cm
- Safety zone: ca. 1826 x 1584 cm
- Total height: 880 cm
- Free fall height: ca. 210 cm

### Materials:

#### Large Tower:

- **Natural posts** made of robinia wood, protected against splitting. The structure is constructed from beams with a diameter ranging between 20-25 cm and a length of 800 cm, which together with the platforms form the main framework. Robinia contains large quantities of oils, which act as an excellent natural preservative protecting the wood from decay and pests.
- **Construction platforms** made from three materials:
  - Frame made of stainless steel AISI 304 fabricated from pipes with diameters of 76.1 x 3 mm and 33.7 x 2 mm, cleaned by shot blasting
  - Platform made of robinia boards and reinforced 10 mm rubber with an anti-slip surface
- **Roof** made from coloured polycarbonate with a thickness of 5 mm
- **Tube slides** manufactured from stainless steel AISI 304, cleaned by shot blasting. Spiral slides are fitted with coloured polycarbonate windows 6 mm thick.
- **Open slide** made from stainless steel AISI 304, cleaned by shot blasting.
- **Tower walls** constructed from robinia boards and stainless steel AISI 304 mesh, fixed to the post by aluminium clamps, protected against corrosion by powder coating.
- **Diamond Passage** between tower levels made from a combination of 13 mm HPL, robinia boards, and 12 mm coloured polycarbonate. Inside the passage, climbing holds are made from a mixture of aggregates and coloured polyester resins.
- **Bars and handles** made of stainless steel AISI 304, tubes with a minimum diameter of 33.7 x 2.0 mm
- **Three-dimensional** climbing net made from 16 mm diameter polypropylene pp-multisplit rope with a steel core and components of reinforced 10 mm rubber with an anti-slip texture. Rope connectors made of injection-moulded polyamide.

#### Small Tower:

- **Natural posts** made of Robinia wood, secured against splitting. Beams used range in diameter from 13-25 cm. These are connected by a specialized spacer made of stainless steel AISI 304 and an M16 stainless steel rod. Robinia contains large quantities of oils, which act as an excellent natural preservative protecting the wood from decay and pests
  - **Climbing walls** and platforms made from Robinia wood.
  - **Tower walls** constructed from natural Robinia wood planks and stainless steel AISI 304 mesh or 12 mm coloured polycarbonate, affixed to the posts using aluminium clamps, protected against corrosion by powder coating.\*
  - **Roof** made from 12 mm coloured polycarbonate.\*
  - **Bars** and structural elements made of stainless steel AISI 304, with a minimum bar diameter of 33.7 x 2.0 mm.
  - **Connectors** manufactured from aluminium alloys. The aluminium is corrosion-protected by powder coating.\*
  - **Slides:** open type, made from stainless steel AISI 304, with sheet metal 2 mm thick.\*
  - **Climbing** holds made from a mixture of aggregates and coloured polyester resins.\*
- **Closed bridge made of multiple elements giving it a unique design:**
- Mesh** of AISI 304 stainless steel, prepared by shot blasting.
  - Roof** made of 5 mm coloured polycarbonate and robinia wood boards.
  - Platform** of 10 mm reinforced rubber with an anti-slip texture.
  - Obstacles** inside the bridge made from 16 mm diameter pp-multisplit polypropylene ropes and handles manufactured from LDPE by rotomoulding.

-All screws and fixings exposed to weather conditions are made of stainless steel.

### The device includes at minimum:

- 2 x Hexagonal towers – platform heights approximately 240 cm, 445 cm, and 650 cm
- 1 x Small square tower with two platforms, one above the other
- 1 x Additional triangular platform made from Robinia wood
- 2 x Three-dimensional climbing nets
- 2 x Roofs for the large towers
- 1 x Roof for the small tower
- 2 x Closed spiral slides – platform height approximately 650 cm
- 1 x Closed straight slide – platform height approximately 240 cm
- 1 x Open slide – platform height 90 cm
- 7 x Diamond-shaped passages between tower levels
- 1 x Climbing wall
- 2 x Closed bridges
- 1 x Stair passage with Robinia balustrades
- 3 x Tall walls constructed from a combination of Robinia planks, 12 mm coloured polycarbonate, or stainless steel mesh

## Materials

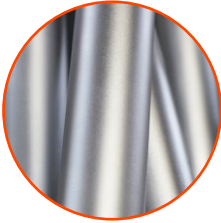

A solid structure made of AISI 304 stainless steel, cleaned using the glass bead blasting process, fully resistant to weather conditions.



Natural posts made of robinia acacia wood, protected against splitting.



Elements made of colourful 13 mm HPL, in the highest quality, totally damp-proof and resistant to UV.

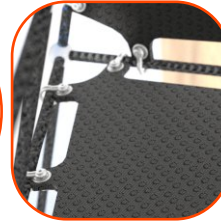

Reinforced rubber, 10 mm thick, with a non-slip surface.

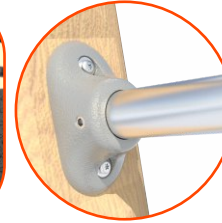

A system of connectors and clamps made of strong aluminium alloys.



Plates of the walls made of colourful triple layered 15 mm HDPE polyethylene, in the highest quality, totally damp-proof and resistant to UV.



Tube slides made of AISI 304 stainless steel, cleaned using a bead blasting process.



Polypropylene ropes PP - Multisplit type with a steel core and a diameter of 16 mm.



Polycarbonate panels with direct printing.



Elements made of coloured polycarbonate 5 and 12mm.

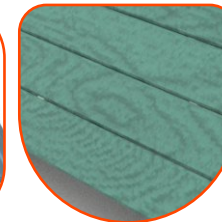

Robinia painted with a special water-based, fast-drying, vapour-permeable paint, providing a semi-gloss finish.